

Roller Skate Express – The Solids

Range of application:

- For short variable ways of transportation.
- Movement of moderately heavy loads, e.g. machines, parts of machines and for installation works.
- A speed of 5 m/min should not be exceeded.
- Allows to turn corners by swivelling. Turntables are placed on top of the skate, handles are to be attached. Only guide with the handle, while the Roller Skate is moving. Minimum turning circle is 3 m.
- The difference in height of skates with the turntables is compensated for by the use of packing plates.
- Easy visual control for the alignment and direction of the load is made by inserting the angle iron into the slots provided on the Roller Skate.

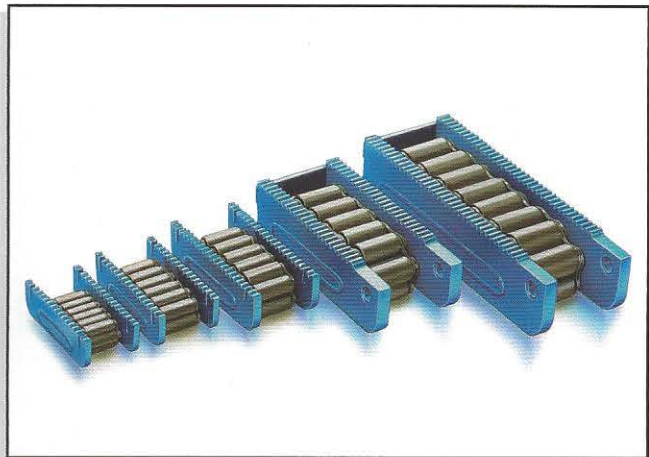

Characteristics of the most sold series Express model... N:

- stable, solid, basic construction
- low level construction
- Accessories for turning corners

Hints on use:

- The track surface is important for the safe transportation of the load, not the carrying capacity of the Roller Skate. Tiles are insufficient. The movement on tarmac and concrete is restricted. In these cases a steel plate of a minimum of 10 mm thickness is recommended.

- Possible problems can be avoided by choosing Roller Skate models with a larger roller diameter within the chain.
- All maximum carrying capacities are based for use on a steel surface, which withstands the high pressure of the chain-rollers. For safety, the carrying capacities on complete sets are calculated so that on uneven surfaces 2 Roller Skates could support the full load.
- Due to the little effort required to overcome the rolling resistance (4-7 % of the total load) precautionary measures must be taken for use on inclined surfaces.

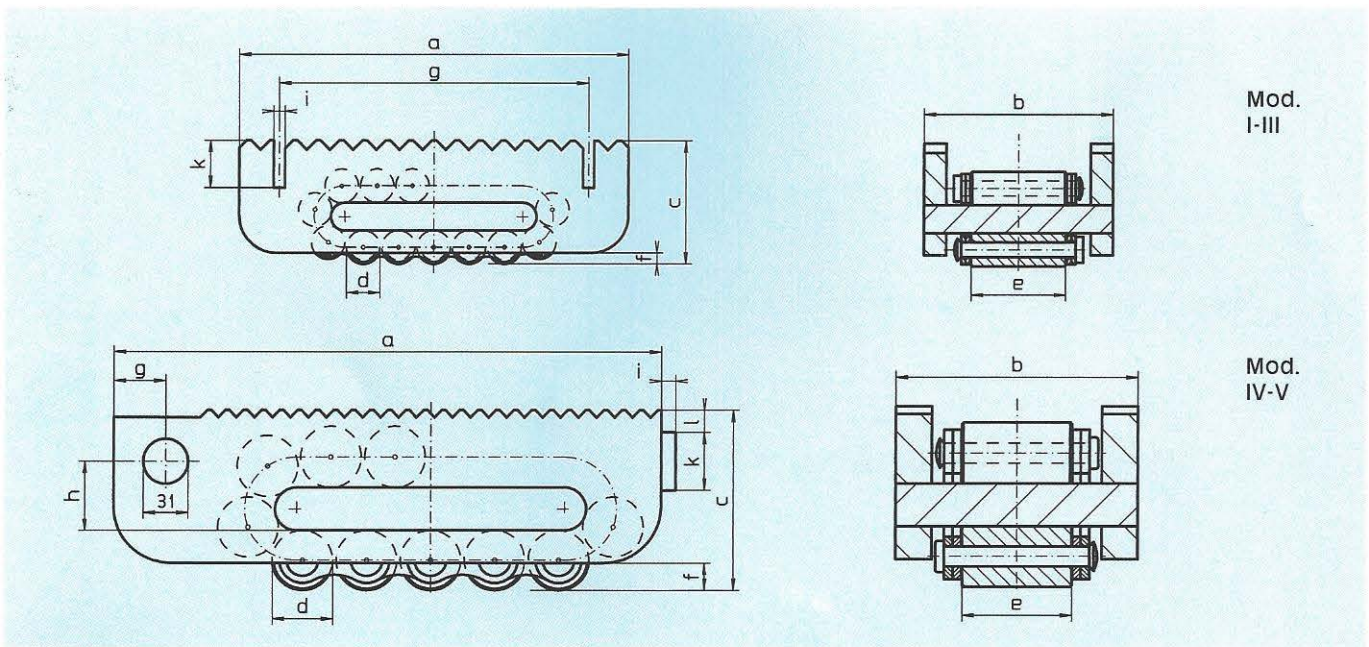

Mod. N

Mod.	a	b	c	Ø d	e	f	g	h	i	k	l	Rollers under stress	Number of rollers	Max. load kN	Weight kg
I	210	100	66	18	51	6	167		6	25		5	15	100	5.2
II	220	113	75	24	60	10	180		6	25		4	13	150	7.3
III	270	130	92	30	68	10	217		6	25		4	13	300	13.0
IV	380	168	127	42	76	16	36	48	10	40	15	4	13	600	32.0
V	530	182	147	50	86	19	36	60	10	40	15	6	17	800	61.0

All dimensions in mm